

# *Energy-saving drive solutions*

Intelligent concepts to cut costs and protect the environment



**Lenze**

# Energy efficiency | the most environmentally-friendly solution

**The UN's latest report on climate change shows that energy consumption by the industrialised nations, most of which currently takes the form of burning fossil fuels, is changing the world's climate.**

The situation is worsened by the rapid economic development of newly industrialised countries. If the per capita energy consumption in these parts of the world were to increase to the level of the world's major economic nations, we would soon run out of primary sources of energy.

We therefore need to reduce our consumption of resources by looking for alternative ways of generating energy and also making more efficient use of the energy we do have. Only by taking this approach will we be able to sustain the levels of production and prosperity we currently enjoy. As a result all industrialised nations have set ambitious targets for reducing their CO<sub>2</sub> emissions.

## **The importance of electric drives**

Almost half the electric energy produced in Europe is used by industry. Electric drives are responsible for around two thirds of this power consumption.

There is virtually no part of the production process, automated transport of material or factory infrastructure that works without electric drives. As electric drives consume a high proportion of total energy and represent a wide range of uses, they are also the most effective lever for improving energy efficiency within industry. A reduction of more than 20% is possible through the use of intelligent solutions.

Better use of energy equates to less pollution, conservation of resources and a reduction in energy costs with the same level of productivity. This will allow us to achieve the same production output with considerably less electric energy.

**Saving energy is one of the biggest challenges we face today and in the future. Lenze is facing up to this responsibility. And we will show you how you can use drives to save energy.**





# Conversion of energy | by drive systems

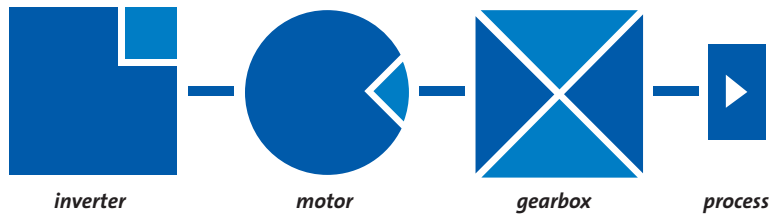

## Lots of little changes deliver a big difference

Most of the drives used in industrial applications have a power output of between 100 watts and several megawatts. Plants in process engineering are dominated by drives with high output power. In contrast, factory automation and logistics centres use drives with a much lower output power but use a large number of them. Several tens of thousands of drives can be found in a typical automotive manufacturing plant. Quite often several thousands of drives are installed in logistics centres. An average industrial plant usually has several hundreds of drives, operating in machines and processes.

## Starting point for energy saving

When evaluating energy use, the entire drive system, comprising inverter, motor and gearbox, should always be considered as the total efficiency determines how much electric energy is required for a defined process. Work often focuses on increasing the efficiency of the electric motor although greater energy savings can in many cases be obtained by optimally adapting the drive to the operating process.

In special applications, the braking energy can also be converted into electric energy rather than releasing it unused into the atmosphere as waste heat.

These figures clearly show that every single drive should be included in an energy analysis. Even those drives that themselves only require a little energy can make a big difference to the total sum of energy consumed if they are used in large numbers.

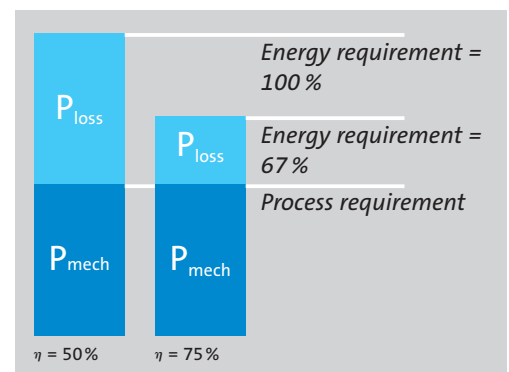
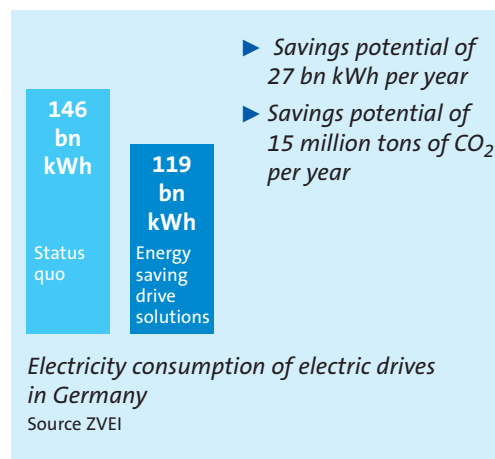

Higher energy efficiency minimises the losses.

# Three ways | to improve energy efficiency

## Energy-efficient drives

There are many parameters that determine the energy efficiency of drives. There are just as many potential starting points for improving energy efficiency. But not all measures produce a clear-cut relationship between effort and result. It is only by analysing the mechanical process and its energy needs that you can establish which measures will be effective and therefore useful for each case.

## Proportion of potential savings

Improving energy efficiency in drives follows three approaches:

1. Using electrical energy intelligently
2. Converting energy with a high degree of efficiency
3. Using the recovered braking energy

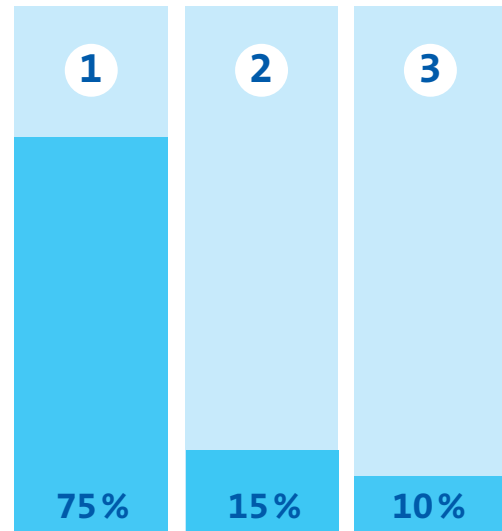

**1. Using electrical energy intelligently: as little as possible**

**2. Converting energy with a high degree of efficiency**

**3. Using the recovered braking energy**

### Concepts with high energy efficiency (should be used)

- ▶ Requirements-based dimensioning
- ▶ Controlled drive (frequency inverter)
- ▶ Energy-efficient open-loop and closed-loop motion control

- ▶ Components with a high degree of efficiency

- ▶ Energy exchange between the drives
- ▶ Intermediate storage of the braking energy
- ▶ Feeding back of the braking energy

### Concepts with low energy efficiency (should be avoided)

- ▶ Oversizing
- ▶ Uncontrolled operation

- ▶ Components with a low degree of efficiency

- ▶ Use of a brake resistor

# Electric energy | used intelligently

In order to make effective use of the energy available, the mechanical energy output by the electric drive must be oriented towards the actual needs of the application. Both the maximum amount of energy needed and fluctuations in operations should be taken into account.

An intelligent, needs-oriented provision of energy therefore needs:

- ▶ the drive to be designed in accordance with the maximum amount of mechanical energy needed
- ▶ the mechanical energy output to be adapted to the prevailing need; something that in many applications fluctuates greatly.

Typical efficiencies of drive systems in partial load operations:

- ▶ at  $0.75 \cdot P_N$ :  $\eta=75\%$
- ▶ at  $0.3 \cdot P_N$ :  $\eta=45\%$

## Accurate design

The optimum efficiency of drive systems often lies in a narrow band around the rated power. Despite this, many drives are oversized to “be on the safe side”. As a result, the drive is operated far below its rated power and efficiency is significantly reduced.

As oversizing also means higher procurement costs, the first measure worth taking when improving energy efficiency is always to accurately orientate the drives to the maximum mechanical energy required by the application. Lenze's **Drive Solution Designer** and its “Energy Performance Certificate” enable selecting a drive system exactly customised to the respective application. This results in lower procurement costs and lower energy consumption.

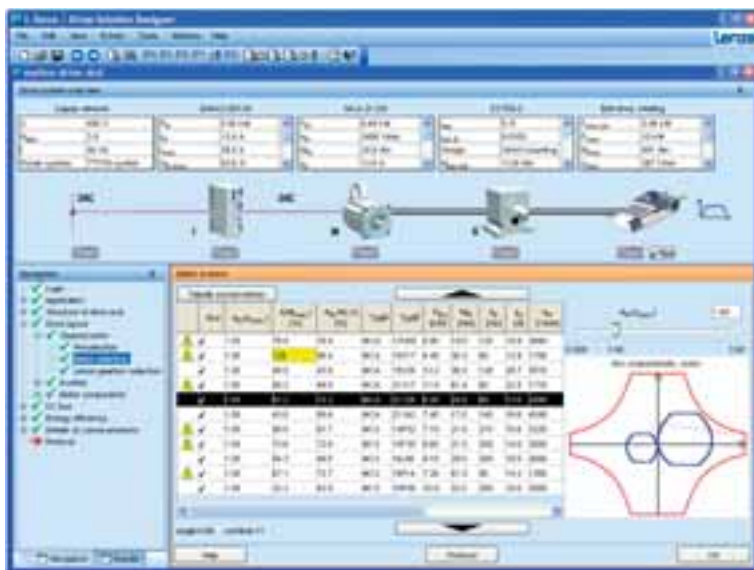

### Speed controlled drives

The amount of energy needed varies in virtually every mechanical process. This is especially the case in cooling and heating systems where the output power of pumps and fans depends on the prevailing ambient temperature. Large fluctuations in the output power needed also arise in materials handling technology if the throughput is not constant.



To improve efficiency, the power output by the motor must be adapted to these different needs. An inverter is used in order to change the motor speed and therefore the output power, the product of speed and torque. Using an inverter greatly improves energy efficiency in virtually all applications. Savings of up to 60% are common in applications with pumps and fans.

### Energy-efficient drive control and motion control

#### Adjusting the operating point

In processes that tend to be constant, adjusting the motor's operating point to the actual load can minimise losses. Using a frequency inverter to adjust the motor voltage produces better efficiency, in particular for partial load operations with standard three-phase AC motors.

#### Energy-efficient motion profiles

Dynamic motion sequences can be designed such that energy efficiency is as high as possible. For example a lot of positioning procedures don't always need the maximum acceleration and braking times. Adjusting to the dynamics actually needed greatly reduces losses in the motor.

#### Energy consumed for positioning applications

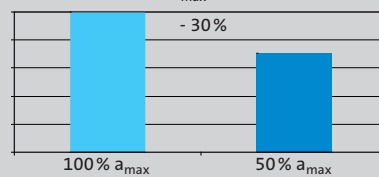
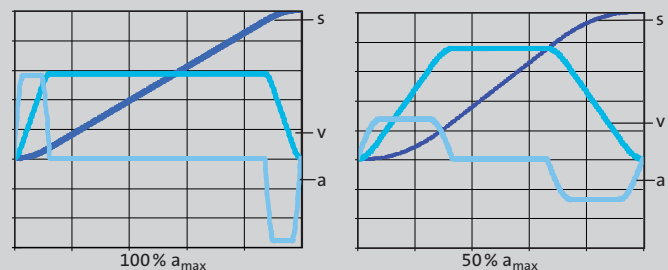

*Reduction of power losses in the motor*

#### Diagnostics by the inverter

In controlled systems, inverters record the status of the drive. This can be used for preventive maintenance, and the designer can reduce oversizing in the design.

# Converting energy | with high efficiency

## Efficiency of drive components

### Inverters

Inverters currently reach a very high efficiency of between 94 and 97%.

### Standard three-phase AC motors

The most commonly used standard three-phase AC motors are available with different efficiency classes. From 2011 onwards, only motors of efficiency class IE2 or higher may be used in the EU. The today most widely used motors of class IE1 will then be forbidden in new installations.

Motors of efficiency class IE3 are significantly larger and more expensive than those of class IE2 with the same power output and should therefore only be used in applications where they are permanently operated at rated speed and high load. Usually the better solution for achieving higher energy efficiency is the use of an inverter that adapts the output power of the drive to the application.

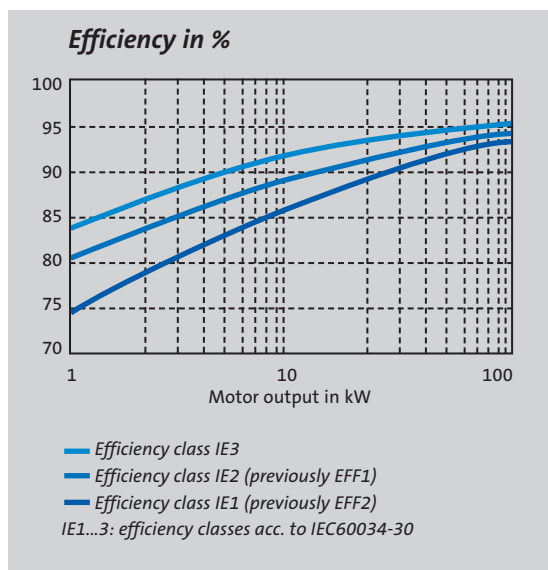

### Synchronous rather than asynchronous servo motors

Controlled drives with asynchronous motors can always be implemented using synchronous servo motors. The motor currents in such drive systems are lower as a permanently excited synchronous motor is not magnetised by the supplied reactive current, but by permanent magnets. This results in better efficiencies than can be achieved with a corresponding asynchronous motor. The amount of energy needed for typical positioning applications drops by 30 %.



But lower motor currents also mean that there is less power loss in the inverter and it may be possible for a smaller inverter to be selected – thereby resulting in improved total drive efficiency. It is therefore well worth checking all applications with controlled drives to see whether a synchronous servo motor with improved energy efficiency would not offer a better solution.

### Energy-efficient gearboxes

Gearboxes adjust the high motor speed to the mechanical process. A ratio of around 20 is most commonly used. This can be achieved at very high levels of efficiency with two-stage helical gearboxes.

Worm and bevel gear toothing is used for right-angle gearboxes. While worm gearboxes generally produce high losses, bevel gearboxes can be produced with good efficiencies.

Further improvements in efficiency are achieved if an inverter or motor of a lower power can be used thanks to the improved efficiency of the gearbox.

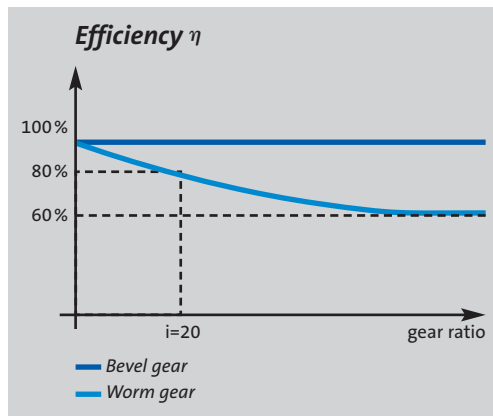

### Energy-efficient mechanical transmission elements

A drive system usually contains passive driving elements like couplings and clutches, bearings, traction drives, guides and both linear and non-linear transmission components. Again there are often several alternatives available offering different levels of efficiency. Keeping friction as low as possible is especially important.

From accurate and optimal installation, increased loads and poor levels of efficiency can be avoided.

### Replacing fluid drives with electric drives

Pneumatic and hydraulic drives are well known for their comparatively low efficiencies. Furthermore, compressed air is expensive and hydraulic oil hazardous to the environment.

Advances in electric drive technology mean that in many cases these problems can be avoided by replacing fluid drives with electric drives. Energy can then be saved at the same time.

	Three-phase AC motor of energy efficiency class IE1 with worm geared motor	Three-phase AC motor of energy efficiency class IE2 with bevel geared motor
Shaft output	0.8 kW	0.8 kW
$\eta$ gear	72%	95%
$\eta$ motor	78%	81%
$\eta$ total	56%	77%
Required motor output	1.5 kW	1.1 kW
Procurement costs	500 €	530 €
Electricity costs per year	490 €	360 €
Total costs in 3 years	1,970 €	1,610 €
Total costs in 3 years	100%	82%
Pay-back period		less than three months

# Braking energy | put to optimum use

## Braking energy

Many applications with electric drives require frequent accelerating and/or braking. When accelerating or lifting, electric energy is converted into kinetic or potential energy, some of which is recovered when braking or lowering.

Nowadays this recovered energy is often converted into heat via a brake resistor and is then lost unused. But in some applications it is well worth passing on this braking energy for another use, thereby improving energy efficiency.

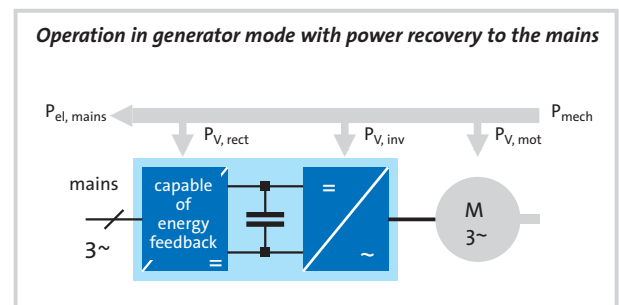
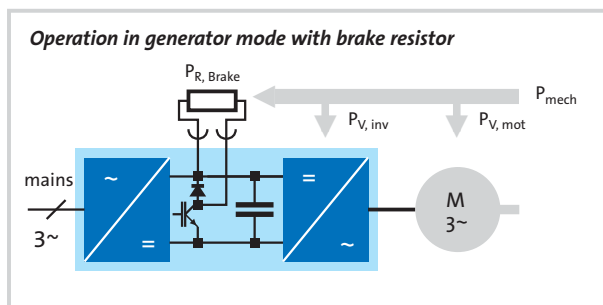

Application	Typical recovery scenarios	Recovered energy	Measure
Conveyor drives	Braking energy is used in the motor	~ 0	None
Travelling drives	Regular but rare recovery when braking	low	Brake resistor, possibly DC-bus connection
Hoist drives	Power recovery during long lowering operations	high	Power recovery, possibly DC-bus connection
Positioning drives	Dynamic recovery with high cycle rates	medium	DC-bus connection, possibly power recovery to the mains
Coordinated drives	Simultaneous occurrence of operations in motor mode and in generator mode	medium	DC-bus connection
Synchronised drives	Sporadic recovery when braking, in some applications continuous braking	low, medium	Brake resistor, DC-bus connection for cont. braking
Winding drives	Continuous braking with unwinders	high	DC-bus connection, power recovery to the mains
Intermittent drives	Dynamic alternation between operations in motor mode and in generator mode with high cycle rates	medium to high	Capacitor accumulator, DC-bus connection, possibly power recovery to the mains
Cam drives	Dynamic alternation between operations in motor mode and in generator mode with high cycle rates	medium to high	Capacitor accumulator, DC-bus connection
Drives for forming processes	In cyclic processes: Dynamic alternation between operations in motor mode and in generator mode	medium to high	Possibly power recovery to the mains
Main drives and tool drives	Continuous operation, sporadic braking	low	Brake resistor, possibly power recovery to the mains
Drives for pumps and fans	Braking energy is used in the motor Coasting of the drive is acceptable	~ 0	None

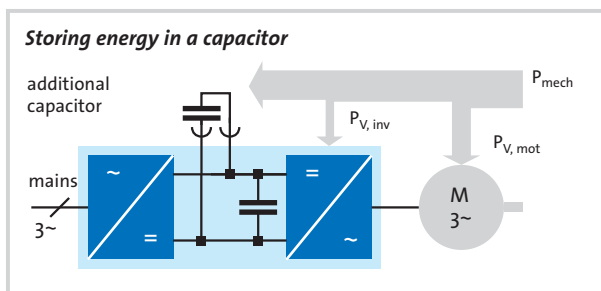
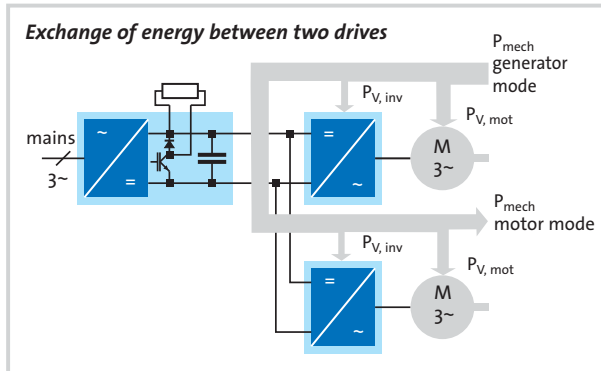

## Ways of using braking energy

### Power recovery into the mains

Most inverters cannot supply energy back to the mains as this process incurs additional cost and is not necessary in many cases. If it is worth recovering power to the mains, an extra regenerative unit must be connected to the DC bus of one or more inverters. It makes economic sense to use a regenerative unit if the output power of the motor exceeds 5 kW.

### Energy exchange between drives

In many applications with significant braking power, there are other drives running in motor mode at the same time. Examples include synchronised drives and unwinders in continuous production lines. In such cases, the inverter's DC buses should be linked (DC-bus connection) to

allow energy to be exchanged directly. A DC-bus connection can also be used to make joint use of a central regenerative unit with several drives and thereby save money.

### Storing energy in a capacitor

Another way in which braking energy can be used is to store it in a capacitor and then make it available again during the next acceleration or lifting procedure. Compared with a regenerative unit, this option is cheaper, but the storage capacity of the capacitor is limited. Energy storage is currently cost-effective for very fast cycled drives.

### Example

Energy storage is sometimes used with intermittent drives for cross cutters. These have to accelerate and brake the roller with the cutter up to ten times a second. The storage approach allows the energy to be moved back and forth between the rotary cutter (kinetic energy) and capacitor (electric charge) during each cutting process. The power consumed from the mains is reduced by at least 50%.



# Life cycle costs | overall cost effectiveness

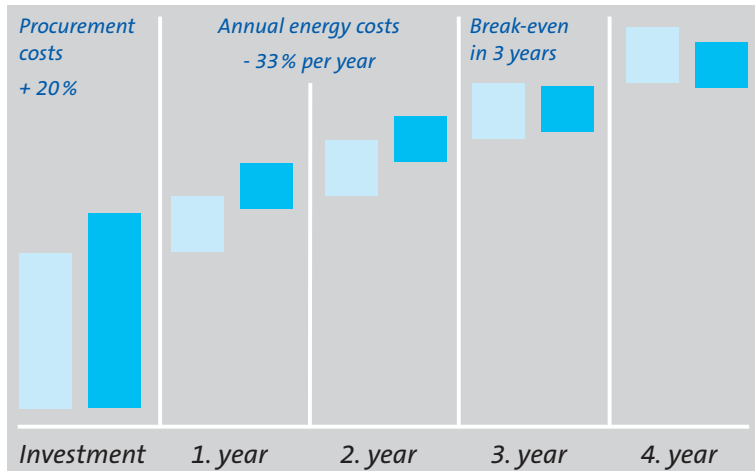

- conventional drives
- energy-efficient drives

Energy costs in drive systems often equate to the procurement costs after just 4 years. Energy-efficient drive systems are often more expensive to buy in the first place than conventional drives but the energy savings achieved mean that the additional costs are usually paid off in a couple of years. The overall cost effectiveness of the drive system can only be assessed as part of a life cycle costs analysis (LCC analysis). This is not an unusual thing to do and has long been a commonly used tool in business management.

LCC analyses are however rare for drives. This is because in the face of tough competition, machine builders often find it hard to encourage customers to buy energy-efficient machines if they are more expensive to buy. But with rising energy costs, in the future the machine operators will increasingly include running costs in their purchasing decisions and expect adequate information from the supplier.

Lenze can assist machine builders in the selection of drives which make up a large part of the machine's energy consumption. This kind of collaboration between operator, machine builder and drive supplier forms the basis for implementing concepts to optimise life cycle costs and therefore energy efficiency.

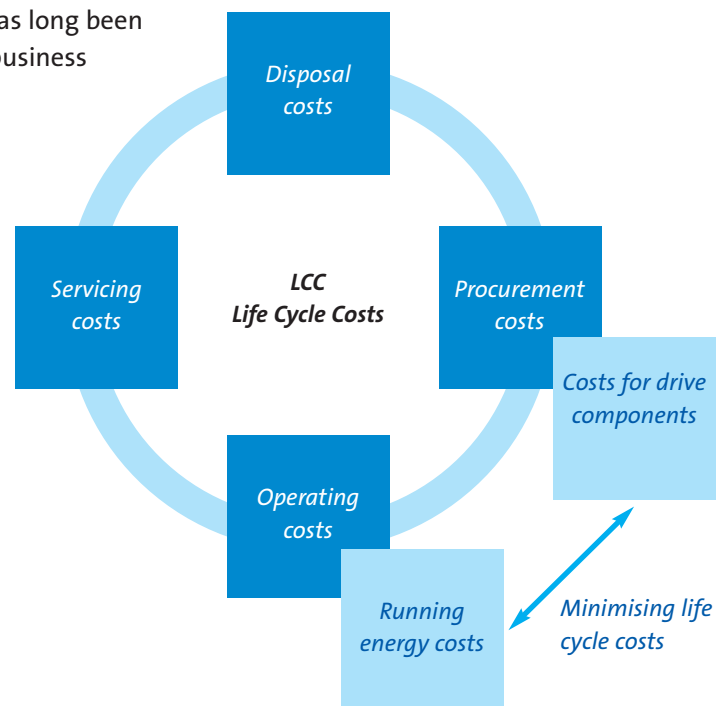

# Drive solutions | the key to energy efficiency

## The twelve drive solutions

Although electric drives may differ greatly in terms of assembly, design and power depending on their area of use, they can be assigned to twelve drive solutions.

The drive solutions differ not only in their functionality but also in the way in which the electric energy is used and converted into mechanical energy. The twelve drive solutions are therefore a good starting point for evaluating and improving the energy efficiency of electric drives. A detailed description of the twelve drive applications can be found in the “Drive solutions” brochure available from Lenze and the book “Drive solutions – mechatronics for production and logistics” (ISBN 978-3-540-76704-6).



Conveyor drives



Travelling drives



Hoist drives



Positioning drives



Coordinated drives for robots



Synchronised drives



Winding drives



Intermittent drives

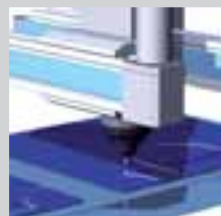

Cam drives



Drives for forming processes



Main drives and tool drives



Drives for pumps and fans

# Energy efficiency | in every drive solution

## Ways of improving energy efficiency

Once the drive requiring optimisation has been assigned to one of the twelve drive solutions, you can also determine which measures will generally be effective, less effective or unsuitable in minimising energy consumption.

The following table shows these measures. It provides the designer with a simple aid to optimising a specific drive application.

## Three ways for improving energy efficiency with drive systems

Improved energy recovery by	1. Using electrical energy intelligently		
	Accurate design	Speed controlled drives	Energy efficient drive control
Low energy recovery by	Oversizing Operation without speed control		
Conveyor drives	●	●	●
Travelling drives	●	●	●
Hoist drives	●	●	●
Positioning drives	○	●	●
Coordinated drives for robots	○	●	●
Synchronised drives	●	●	
Winding drives	●	●	●
Intermittent drives	○	●	●
Cam drives	○	●	●
Drives for forming processes	●	●	
Main drives and tool drives	●	●	●
Drives for pumps and fans	●	●	●

- Standard practice
- Potential energy savings
- Potential energy savings in some applications

Saving energy is one of the biggest challenges we face today and in the future. Contact us, we'd be happy to help you save energy using drives.

2. Converting energy with a high degree of efficiency				3. Using the recovered braking energy		
Asynchronous motor with high efficiency	Synchronous motor	Gearbox with high efficiency	Electric drive instead of fluid drive	Exchange of energy by DC-bus connection	Capacitor storage	Energy recovery to the mains
Drive component with low efficiency				Brake resistor in applications with a high amount of regenerative power		
●		●				
●		●		○		
●		●	●	○		●
	●		●	●		○
	●			●		
●		●		○		
●		●		●		●
	●		●	●	●	○
	●		●	●	●	○
●	●	●	●			○
●	●					○
●	○	●				

# It's good to know | why we are there for you



*"Our customers come first. Customer satisfaction is what motivates us. By thinking in terms of how we can add value for our customers we can increase productivity through reliability."*



**Vitamin L:**  
*Ideas and added value for your drive and automation solutions.*



*"We will provide you with exactly what you need – perfectly co-ordinated products and solutions with the right functions for your machines and installations. That is what we mean by 'quality'."*



*"Take advantage of our wealth of expertise. For more than 60 years now we have been gathering experience in various fields and implementing it consistently and rigorously in our products, motion functions and pre-configured solutions for industry."*



*"We identify with your targets and strive towards a long-term partnership which benefits both sides. Our competent support and consultation process means that we can provide you with tailor-made solutions. We are there for you and can offer assistance in all of the key processes."*

**You can rely on our service. Expert advice is available 24 hours a day, 365 days a year, in more than 30 countries via our international helpline: 008000 24 Hours (008000 2446877).**

**[www.Lenze.com](http://www.Lenze.com)**

13290318